

変更履歴		REMARKS		
符号	変更管理番号	日付	担当	承認
SYM	REVISIONS	DATE	SIGN	APPROVED
△	92021710	1992,2,17	Y.Y	-
△	22092901	2022,9,29	T.H	M.Y

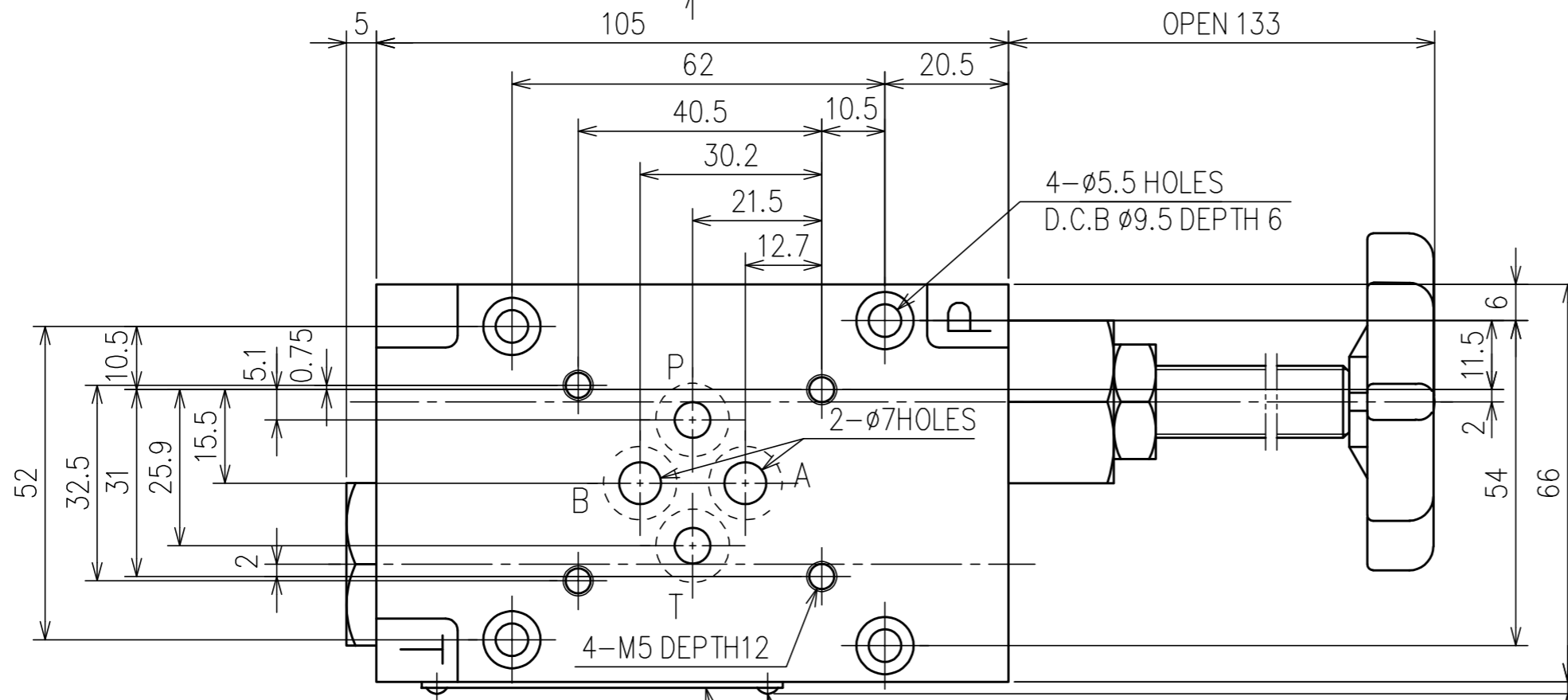
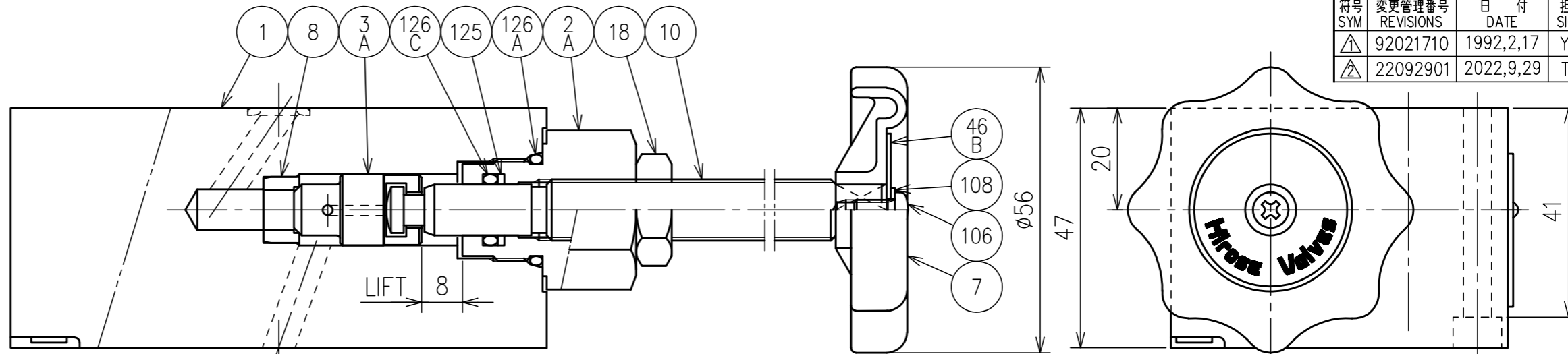
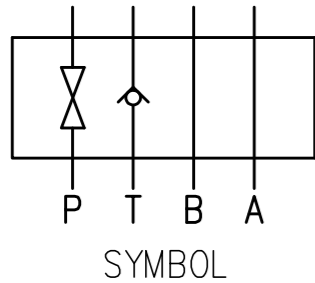

CONFIGURATION OF MODEL No.

JMV-01-SC-T\*\*\*-Y2

- STEM IS SPECIAL
- T PORT CRACKING PRESSURE
- T PORT IS CHECK VALVE
- P PORT IS STOP VALVE
- SIZE

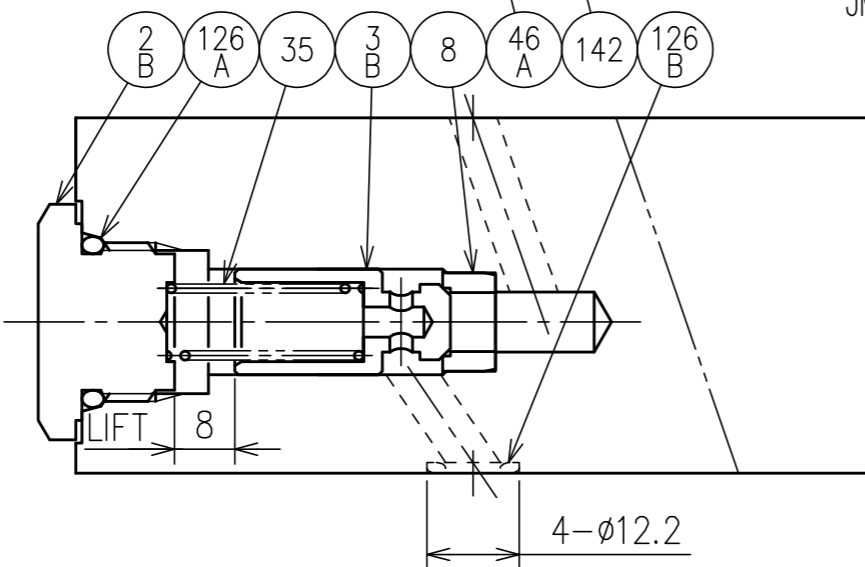

CRACKING PRESSURE (MPa)	INDICATION **	REMARKS
0.035	NO INDICATION	STANDARD
0.1	10	
0.2	20	
0.35	35	
0.5	50	

品番 NO.	部品名 NAME OF PARTS	数量 REQ.D NO.	備考 REMARKS
142	RIVET	2	
126C	O-RING	1	OR NBR-70-1 P10A-N
126B	O-RING	4	OR NBR-90 P9-N
126A	O-RING	2	OR NBR-90 P18-N
125	BACK-UP RING	1	BR JIS B 2401-4 -T2-P10A
108	TOOTHED LOCK WASHER	1	
106	MACHINE SCREW	1	
46B	NAME PLATE	1	
46A	NAME PLATE	1	
35	SPRING	1	
18	LOCK NUT	1	
10	STEM	1	
8	SEAT RING	2	
7	HANDLE	1	
3B	POPPET	1	
3A	DISC	1	
2B	BONNET	1	
2A	BONNET	1	
1	BODY	1	

最高使用圧力 / MAX. WORKING PRESSURE	25 MPa	承認 APPROVED	M. YASUTOMI
質量 / MASS	2.4 kg	検閲 CHECKED	T. TANAKA
接続方法 / COUPLING TYPE	MODULAR	製図 DRAWN	S. NAKAI

名称 NAME 1/8B MAINTENANCE VALVE

形式 MODEL NO. JMV-01-SC-\*\*\*-Y2

廣瀬バルブ工業株式会社 / HIROSE VALVE INDUSTRY CO., LTD.

日付 DATE 1987,1,17 図番 DRAWING NO. ES-5655